



CITY COUNCIL

May 20, 2019

A regular meeting of the City of Petoskey City Council was held in the City Hall Council Chambers, Petoskey, Michigan, on Monday, May 20, 2019. This meeting was called to order at 7:00 P.M.; then, after a recitation of the Pledge of Allegiance to the Flag of the United States of America, a roll call then determined that the following were

Present: John Murphy, Mayor
Kate Marshall, City Councilmember
Suzanne Shumway, City Councilmember
Grant Dittmar, City Councilmember
Lindsey Walker, City Councilmember

Absent: None

Also in attendance were City Manager Robert Straebel, Clerk-Treasurer Alan Terry, City Planner Amy Tweeten, Parks and Recreation Director Kendall Klingelsmith and Downtown Director Becky Goodman.

Consent Agenda - Resolution No. 19295

Following introduction of the consent agenda for this meeting of May 20, 2019, City Councilmember Marshall moved that, seconded by City Councilmember Shumway adoption of the following resolution:

BE IT RESOLVED that the City Council does and hereby confirms that the draft minutes of the May 6, 2019 regular session City Council meeting be and are hereby approved; and

BE IT RESOLVED that receipt by the City Council of a report concerning all checks that had been issued since May 6, for contract and vendor claims at \$845,350.92 intergovernmental claims at \$0, and the May 16 payroll at \$212,694.25, for a total of \$1,058,045.17 be and is hereby acknowledged.

Said resolution was adopted by the following vote:

AYES: Marshall, Shumway, Dittmar, Walker, Murphy (5)

NAYS: None (0)

Hear Public Comment

Mayor Murphy asked for public comments and there was a comment concerning Harbor Hall and that the project should be monitored closely; concerns with medical marijuana and cash deposit issues into banks; that large firms are coming into the area interested in medical marijuana provisioning centers causing real estate values to increase and that other areas should be increased for proposed uses; and heard from those opposed to marijuana and that it shouldn't be allowed in Petoskey and will destroy the community.

Hear City Manager Updates

The City Manager reported that the Petoskey Harbor Springs Community Foundation recently awarded a \$25,000 grant to the Groundworks Center for Community Resiliency to fund a clean energy policy specialist for the City of Petoskey and that the City will collaborate on several clean energy initiatives in the future; that the Community Foundation also recently awarded the City \$6,000 in grant funding to perform two more energy audits for City buildings; that the City Attorney does not know of any legal mechanism to require property owners to more readily rent out their vacant properties; that the cement needs to be removed in some areas near the downtown bathrooms due to shoddy workmanship, improper leveling and inconsistent curb heights and joints, but will be in service for the Memorial Day weekend; that the Bayfront Park retaining wall and US-31 realignment project is progressing with the wall substantially complete; that the Wheelway should be open by June 1 contingent upon weather and will be further widened thereafter; that the spring rubbish program begins tomorrow and mattresses will not be collected this year, but can be recycled at Emmet County Pleasantview Drop-off Center; that a potential ferry service for the Harbor Springs and Petoskey area is being reviewed by the Parks and Recreation Commission, and approval is first contingent upon Harbor Springs approval; that a status update of the 2018 Action Plan will be reviewed at the next meeting; that the Planning Commission continues to review medical marijuana zoning issues and the Harbor Hall expansion project discussion will continue with review of site plan standards at their June 13 meeting; and that the City Manager will be out of the office on vacation Thursday afternoon and all day Friday.

City Councilmembers commented that there is a lot of cement as part of the wider highway realignment project and that there needs to be adequate landscaping; inquired on the status of 100% renewable energy resolution; that the Groundworks Center is conducting a conference this week in Traverse City on renewables and that several Councilmembers would be attending; inquired on the potential ferry service and where the boat would be docked; and if the Fabiano property was being demolished only due to the roof condition.

The City Manager responded that MDOT and City will provide landscaping as part of the highway project; that staff would like MPPA to see what the process should be and review the renewable energy resolution; that the proposed ferry would be docked at the Marina in a 42' slip; and that the Fabiano property was being demolished because of the roof condition.

Mayor Murphy asked for public comments and heard an inquiry on waterproofing of retaining wall and how often it will be done and by whom, and why Public Safety West was receiving an energy audit since it was designed and built just a few years ago.

The City Manager responded that the fire station was built some time ago and the energy audit can provide staff with helpful tips and new technology. MDOT would be expected to maintain the US-31 retaining wall.

Local Historic District Study Committee Appointments – Resolution No. 19296

Mayor Murphy reviewed that City Council consider possible appointments to the Local Historic District Study Committee.

City Councilmember Walker moved that, seconded by City Councilmember Marshall adoption of the following resolution:

BE IT RESOLVED that the City Council does and hereby approves the appointment of Ann Ingles, 1305 Waukazoo Avenue, Paul Krecke, 317 ½ East Mitchell Street, Rick Neumann, 610 Grand Avenue, Jennifer Shorter, 7017 Stanley Court, and Reginald Smith, 515 Lockwood Avenue, to the Local Historic District Study Committee.

Said resolution was adopted by the following vote:

AYES: Marshall, Shumway, Dittmar, Walker, Murphy (5)

NAYS: None (0)

Adopt Ordinance 770 Concerning Fences – Resolution No. 19297

The City Planner reviewed that on May 6 the proposed ordinance to amend Section 201 and replace Section 1712 Appendix A concerning fences was introduced with no action taken. This was a second meeting on the proposed ordinance which could be approved by City Council.

City Councilmember Marshall moved that, seconded by City Councilmember Dittmar adoption of the following ordinance:

ORDINANCE NO. 770

AN ORDINANCE TO AMEND SECTION 201 AND REPLACE SECTION 1712 OF APPENDIX A, ZONING ORDINANCE, OF THE PETOSKEY CODE OF ORDINANCES

The City of Petoskey ordains:

1. **Section 201 of Appendix A to the Petoskey Code of Ordinances is hereby amended to add the following definitions:**

Corner Clearance: Any obstruction within the vision triangle that is more than two (2) feet higher than the street midpoint.

Corner-front yard: the secondary street-fronting yard of a corner lot not included in the property address.

Fence: A constructed barrier erected to enclose, screen, or separate parcels.

Fence, Decorative: A fence, no more than 3 ½ feet (42 inches) in height measured from the established grade to the top of the highest fence post, no less than 50% open, and intended primarily as an ornament or accent on a parcel such as a picket, wrought iron, split rail or similar material. Chain link (with or without vinyl covering), wire mesh, wood stockade, and snow fencing shall not be considered decorative fencing.

Fence, Living: A hedge or row of bushes planted with the purpose of screening a yard.

Fence, Privacy, Screening, Security: a fence no more than six (6) feet in height intended primarily to screen or provide security to property.

Vision Triangle: the area at an intersection formed by extending a straight line 20 feet along the back of each curb from its radius spring point and connecting these two points (See Figure 8).

FIGURE 8

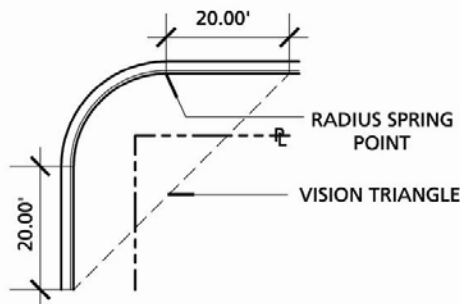

2. **Section 1712 of Appendix A to the Petoskey Code of Ordinances is hereby repealed and replaced with the following:**

Sec. 1712. Fences (Single and two-family residential).

All fences shall require a zoning compliance permit issued by the Zoning Administrator and shall comply with the following regulations and requirements.

1. Location (see Figure 1712)

- a. Corner-Front Yard. Only decorative and living fences are allowed within a corner-front yard with a minimum setback of two (2) feet from the street-fronting property line.
- b. Side and Rear Yards. Fences may be placed up to a lot line in side and rear yards.
- c. Fences shall be located so as to not obstruct corner clearance or vision of motorists exiting driveways.
- d. No fence shall be placed within the City right-of-way and if so placed shall be removed at the owner's expense.
- e. Underground electric fences shall be set a minimum of five (5) feet from a front or corner-front property line.

2. Height and Design Restrictions.

- a. Side and rear-yard fences shall not exceed six (6) feet in height and shall not extend beyond the principal structure into a front yard.
- b. Corner-front yard decorative fences shall not exceed 3 ½ feet (42 inches) in height and shall not obstruct vision to an extent greater than fifty (50) percent of total area.
- c. Chain link fences are only allowed in rear and side yards.
- d. Living fences shall not exceed three (3) feet in height in a corner-front yard, shall be placed so that growth is kept at least two (2) feet from the property line, and shall not contain invasive species.
- e. Fences that enclose public or institutional parks, playgrounds, or public landscaped areas, situated within an area developed with recorded lots shall not exceed eight (8) feet in height, measured from the surface of the ground.
- f. Fences may be placed on retaining walls, berms or similar features with the fence height to be measured from the established grade.
- g. All fences shall have the finished side facing the adjacent property or public right-of-way.

3. Maintenance of nuisances

Fences shall be maintained so as not to endanger life or property. Any fence which, through lack of repair, type of construction, or otherwise, endangers life or property is hereby deemed a nuisance per Chapter 13 of the Petoskey Code of Ordinances.

Figure 1712

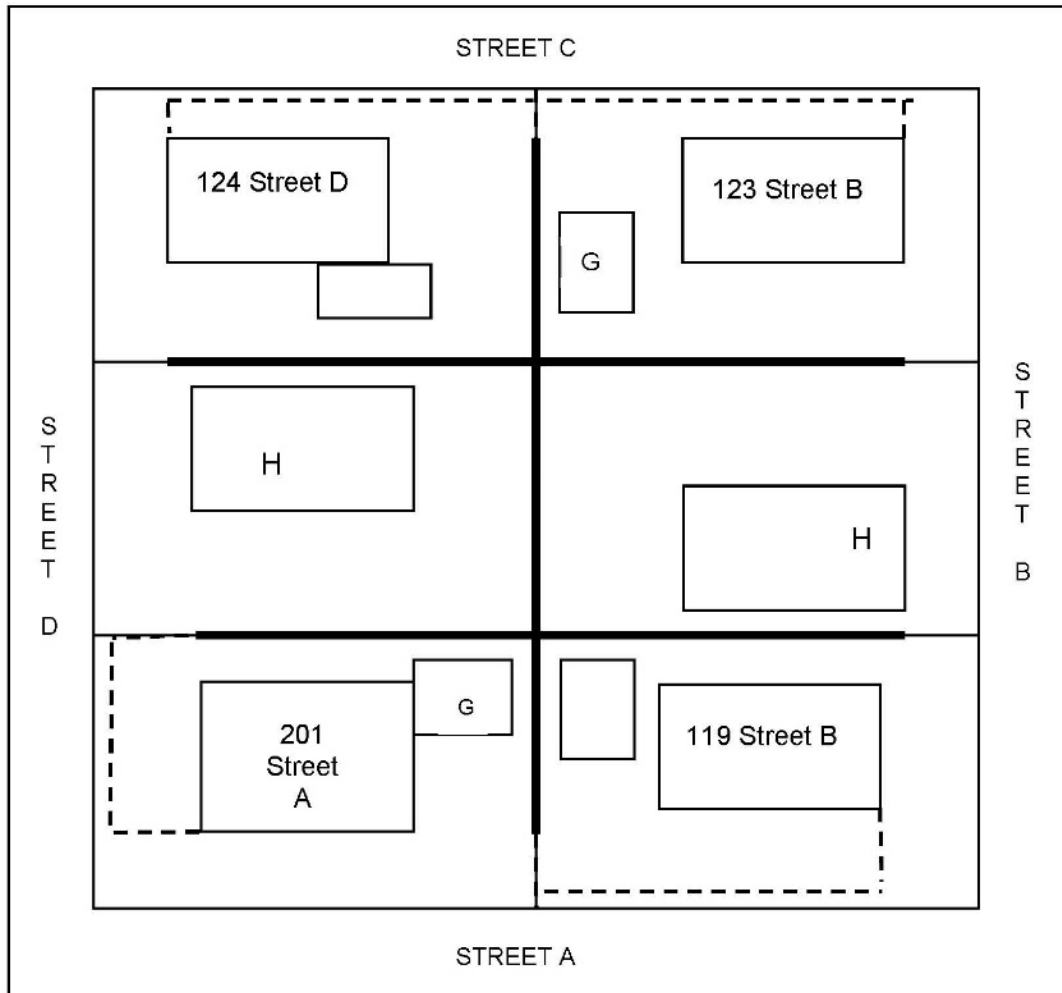

----- In a corner-front yard only decorative fences, maximum 3 ½ feet in height, 50% open or living fence, maximum 3 feet in height allowed two (2) feet from property line

————— Maximum 6 Ft. Fence Allowed

3. **Conflicting Standards.**

If any of the standards set forth in this amendment conflict with any other standards of previous or further ordinances or amendments, the stricter standards shall apply.

4. **Repeal; Savings Clause.**

All ordinances, resolutions, or orders, or parts thereof, in conflict with the provisions of this ordinance are, to the extent of such conflict, repealed.

5. **Severability.**

The various parts, sections and clauses of this Ordinance are hereby declared to be severable. If any part, sentence, paragraph, section or clause is adjudged unconstitutional or invalid by a court of competent jurisdiction, the remainder of the Ordinance shall not be affected thereby.

6. **Effect.**

This ordinance shall take effect fifteen (15) days following its enactment and shall be published once within seven (7) days after its enactment as provided by Charter.

Said ordinance was adopted by the following vote:

AYES: Marshall, Shumway, Dittmar, Walker, Murphy (5)

NAYS: None (0)

Discuss City Manager Performance Evaluation Form

The City Manager reviewed that Councilmembers directed the City Manager at the May 6 meeting to bring forth examples of performance evaluation forms specifically for a city manager position and that 9 examples were provided.

City Councilmembers were both in favor and opposed to using number values; heard from those that favored City of Richmond's form; heard comments that the intergovernmental relationship section be included from City of Durand; and that the two forms from Richmond and Durand be combined and brought back for Council review.

Authorize Fire Station Overhead Door Replacement Contract – Resolution No. 19298

The Parks and Recreation Director reviewed that the 2019 CIP and Annual Budget included \$40,000 for replacement of the four overhead doors fronting Lake Street for the main fire station; that the doors, infrastructure and two of the operators are 30 years old and damaged; that improvement is necessary for the efficiency and safety of the fire station's operation; that Petoskey Architect Nick White and staff prepared detailed bid specifications; bids were advertised and made available on April 18; and that one bid was received and was opened publicly on May 14. The architect and staff reviewed that the base bid of \$31,123.47 is adequate, however for an additional \$2,466.17 Preston Feather Building Centers, Petoskey, will upgrade four existing door tracks from a 2-inch to a 3-inch heavy duty high-lift track and upgrade all four operators, which City staff is recommending.

Mayor Murphy asked for public comments and heard an inquiry on how the timing of the door replacement would affect the energy audit.

The Parks and Recreation Director responded that replacement is necessary and that the energy audit would be based on past energy history and use.

City Councilmember Marshall moved that, seconded by City Councilmember Shumway to authorize contracting with Preston Feather Building Centers, Petoskey, for replacement of four overhead doors and track at the Lake Street Fire Station in the amount of \$33,589.64.

Said motion was adopted by the following vote:

AYES: Marshall, Shumway, Dittmar, Walker, Murphy (5)

NAYS: None (0)

Introduction of a Proposed Ordinance Concerning Fireworks

The City Manager reviewed that Public Act 256 addressing consumer use of fireworks in Michigan took effect in 2011; that Public Act 635 amends Public Act 256 and became effective December 28, 2018; that previously the Act allowed 30 specific dates local jurisdictions could not restrict the use of consumer fireworks; reviewed that recently passed Public Act 635 significantly reduced the number of days protected by this restriction; reviewed the State statute; and reviewed that the City's current ordinance regarding fireworks is not consistent with current State law.

City Councilmembers inquired on what types of fireworks were allowed and if local municipalities could be more restrictive, and if the City could be more restrictive to times rather than the 11:45 P.M. ending time.

City Council will further review the proposed ordinance at the next regular scheduled meeting.

Establish 2018 Tax Millage Rates – Resolution No. 19299

The Finance Director reviewed the proposed 2019 millage rates and tax revenue. City Council approved the 2019 Annual Budget at their November 19, 2018 meeting which included a provision for property-tax millage rates to remain the same as in 2018. City Council was now being asked to formally establish the millage rates necessary to provide the budgeted property-tax revenue approved in the 2019 Annual Budget for the General Fund, Library Fund and Right-of-Way Fund.

The Finance Director reviewed total millage rates; taxable values and State's inflation rate and that the City is required to roll back millage rates; and reviewed property tax revenues that will be collected from each levy including general operating, solid waste, public safety equipment, library and right-of-way.

City Councilmember Dittmar moved that, seconded by City Councilmember Marshall adoption of the following resolution:

WHEREAS, as required by City Charter provisions, the City Manager on November 5, 2018 presented to the City Council the City's proposed annual budget for the 2019 fiscal year; and

WHEREAS, as also required by City Charter provisions, the City Council on November 19, 2018, conducted a public hearing to receive comments concerning the proposed budget, including rates of property-tax millages that had been estimated for levies during 2019; and

WHEREAS, following its review of the proposed 2019 Annual Budget, and after conducting a public hearing to receive comments concerning the proposed budget and estimated tax levies, the City Council on November 19, 2018, approved the 2019 Annual Budget:

NOW, THEREFORE, BE IT RESOLVED that the City of Petoskey City Council does and hereby directs that there shall be raised through a general tax upon the taxable real and personal property within the City during the next summer tax levy for the year commencing January 1, 2019, millages in the amount of 7.5327 for general operating purposes, 0.4890 for solid-waste purposes, 0.7426 for Public Safety equipment purchases, 1.7810 for library purposes, and 3.8790 for right-of-way purposes; and, when collected, proceeds from such levy are hereby appropriated to the General Fund, Library Fund, and Right-of-Way Fund; and

BE IT FURTHER RESOLVED that the total aggregated amount of all such authorized millages shall total 14.4243 mills; and

BE IT FURTHER RESOLVED that these various millages so ordered to be levied shall be certified by the City Clerk-Treasurer to the City Assessor and shall be levied and collected upon the taxable value of all taxable property within the City.

Said resolution was adopted by the following vote:

AYES: Marshall, Shumway, Dittmar, Walker, Murphy (5)

NAYS: None (0)

Approve City Ward and Convention Schedule and Dates – Resolution No. 19300

The City Manager reviewed that as required by City Charter provisions, Council was being asked to approve schedule and times and designate locations for conducting annual Ward and City Conventions. In order to comply with the State's filing deadlines for candidates, the City Manager recommended that the four Ward Conventions be scheduled simultaneously for 8:00 P.M., Monday, July 8, and that the City Convention be called for 8:00 P.M., Wednesday, July 10.

The City Manager recommended that Ward Conventions be conducted at the City Hall Council Chambers (First Ward), Ottawa Elementary Media Center (Second Ward), Lincoln Media Center (Third Ward) and Spitler Administration Building Board Room (Fourth Ward). The City Convention will convene at the North Central Michigan College Library Conference Center.

City Councilmember Shumway moved that, seconded by City Councilmember Walker adoption of the following resolution:

WHEREAS, in accordance with provisions of the City Charter, the City Council must establish dates and places for annual Ward Conventions and the annual City Convention:

NOW, THEREFORE, BE IT RESOLVED that the City of Petoskey City Council does and hereby calls the annual 2019 Ward Conventions to be held at 8:00 P.M., Monday, July 8, at the City Hall Council Chambers for the First Ward, Ottawa Elementary Media Center for the Second Ward, Lincoln School Media Center for the Third Ward, and Spitler Administration Building Board Room for the Fourth Ward; and

BE IT FURTHER RESOLVED that the City Council does and hereby calls the annual 2019 City Convention to be conducted at 8:00 P.M., Wednesday, July 10, at the North Central Michigan College Library Conference Center.

Said resolution was adopted by the following vote:

AYES: Marshall, Shumway, Dittmar, Walker, Murphy (5)

NAYS: None (0)

Council Comments

Mayor Murphy asked for Council comments and there were no comments.

There being no further business to come before the City Council, this May 20, 2019, meeting of the City Council adjourned at 8:07 P.M.

John Murphy, Mayor

Alan Terry, Clerk-Treasurer